

SF SERIES STAINLESS STEEL SELF-PRIMING JET PUMP INSTRUCTION MANUAL

Model	Power(P ₂)		MAX. Suction (m)	Bore (inch)		Flow Q	L/min m ³ /h	5	15	20	30	40	50
	kW	HP		in	out			0.3	0.9	1.2	1.8	2.4	3.0
SF037	0.37	0.5	9.0	1	1	Head (m)		31	25	23	19	14	9
SF75	0.55	0.75		1	1			34	29	26	23	19	16
SF100	0.75	1.0		1	1			38	32	30	25	22	19
SF150	1.0	1.33		1	1			47	42	39	34	31	30

220v/60hz,110v/60hz models are available on request

This symbol together with one of the following words "Danger" or Warning indicates the risk level deriving from failure to observe prescribed safety precautions.

DANGER risk electric shock Warns that failure to observe the precautions involves a risk of electric shock.

DANGER Warns that failure to observe the precautions involves a risk of damage to persons and /or things.

WARNING Warns that failure to observe the precautions involves a risk of damaging the pump and /or the plant.

1.Specification

This manual has been conceived to offer the adequate information on the installation, operation and maintenance of our electro pumps. We suggest you read it thoroughly. These are centrifugal horizontal electro pumps with self-priming capacity and supplied with century system so to reach suction of up to 9 mts. Connect a foot valve and the pump will get an immediately self-priming. They have been designed to operate with clean water at a maximum temperature of 45°C. Operating with any kind of water, other than that just described should be avoided. These pumps have been built with first quality materials which submitted to strict hydraulic and electric controls and verified thoroughly. Following these present instructions and the electrical chart, will help you to achieve a correct installation. If failure to do this could result in motor overcharge and any other consequences, which we wish to be relieved of.

2.Installation

The electric pumps must be placed as possible to the water level in order to obtain the minimum suction lift and reduce the loss of head. If the installation is permanent, pump should be attached to the floor or ground using the holes pump bracket.

They should be installed in dry place and safe from any possible flooding.

3.Pipe assembly

The suction pipe must be resistant to depression and be kept submerged 30 cms below water level to prevent the formation of whirs and its inscurability consequence: Air leaks if suction lift is over 7 mts. the use of a pipe of a bigger diameter than the admission port of the pump is recommended. the unions or connections must be absolutely water-tight. It is recommended to reduce pipe bends to the minimum inclination of 2%. The discharge pipe should have a diameter equal or bigger than of the pump outlet. In any case should the suction or discharge pipes rest on top of the pump.

4. Electrical connection

⚠ The electric installation should be provided by a system of multiple separations with contact openings of at least 3 mm.

The protection of the system will be made by a differential switch (1fn=30mA.) The electric cable must correspond to the EEC(2) norm or to the type H07 RN-F according to VDE 0250.

The single phase motors have a built-in thermal protection.

Look at the schematic drawing on Fig(1) for a correct electrical connection.

5. Controls prior to the initial starting

- ⚠
- Check that the tension and frequency of the electric supply correspond to that indicated on the technical characteristics label.
 - Make sure that the shaft rotates freely.
 - Fill pump body with water, unscrewing slightly the priming plug.
 - Verify the motor sense of rotating as indicated on the fan cover.
 - **THIS PUMP SHOULD NEVER BE DRY OPERATED.**

6. Starting

- Open all gate valves installed in the suction and connect the electric supply switch and wait for the priming to be completed. If a foot valve has been installed, the priming will be instantaneous.
- If motor fails to start or does not deliver water.
- Refer to our "trouble Shooting" list with the possible problems and consequent actions to take. This information will be found on the next pages.

7. Maintenance

□ Our electro pumps do not need any special maintenance.

Pump body should be drained during periods of low temperatures or long period of inactivity. If this inactivity last longer, pump should be cleaned and kept in a dry and aired place.

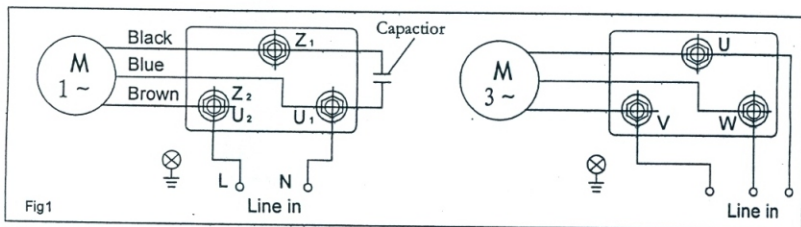

Performance Curves

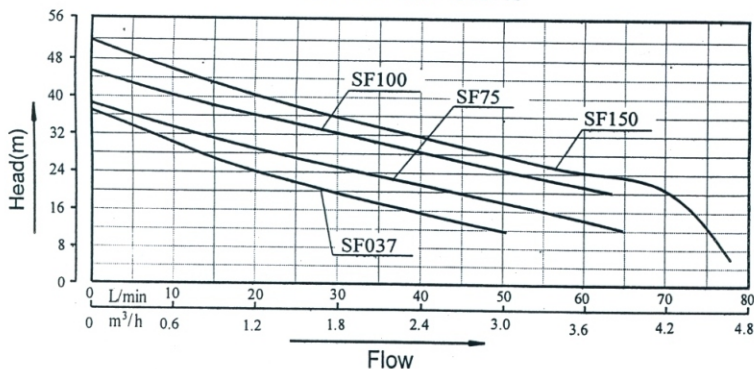

Overall dimension

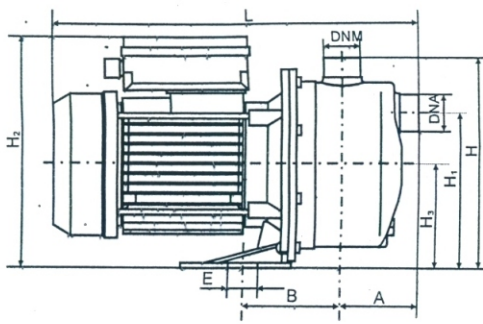
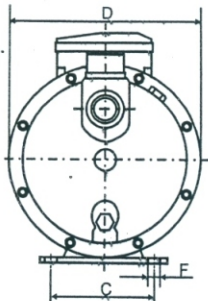

Model	A	B	C	D	E	F	H	H ₁	H ₂	H ₃	L	DNA	DNM
SF037	88	109	100	170	7	7	178	128	195	88	365	G1	G1
SF75	80	80	98	184	20	10	203	157.5	202	98	354	G1	G1
SF100	80	80	98	184	20	10	203	157.5	202	98	354	G1	G1
SF150	97	162	98	198	80	10	212	160	236	105	417	G1	G1

Possible faults causes and solutions

SYSTEM PROBLEM	POSSIBLE PROBLEM	SOLUTIONS
The motor does not start. Motor starts and stops continuously.	Pump blocked.	Disconnect it and take it to the Official Technical Service.
Flow is insufficient	Foot valve clogged	Clean it or replace by new one
There is no suction. Flow is insufficient	Total manometric head higher than expected.	Verify geometric head and loss of head.
The motor does not start. Motor over-heating. Motor starts and stops continuously.	Wrong tension.	Check that the tension is the same as that on the technical characteristics label.
There is no suction. Motor runs but it gives no pressure. Flow is insufficient.	Water level in well or tank has come down.	Verify suction head.
The motor does not start.	Fuse or thermal relar disconnected.	Change fuse or thermal relar.
Motor runs but it gives no pressure. Flow is insufficient.	Impellers are worn out.	Disconnect pump and take it to your Service Dealer.
There is no suction. Motor runs but it gives no pressure.	Foot valve not submerged.	Be sure suction pipe is submerged.

There is no suction. Motor runs but it gives no pressure.	Pump was not primed.	Fill pump body with water.
Motor over-heating. Motor starts and stops continuously.	Room not properly aired.	Provide good ventilation.
There is no suction. Motor runs but it gives no pressure.	Air entry.	Disassemble and take it to your official Service Dealer.
Flow is insufficient.	Venturi clogged.	Seal unions and joints properly.

Our company reserve privilege right of promoting design and using material without notification previously.

